

ELECTRIC M12.25S WINCH - TERRAFIRMA

Defender Mk I

Defender Mk II

Part Number: **TF3320**



Mounting Your Winch

1. Choose a suitable location to mount the winch that is strong enough to withstand the loads. A mounting plate is recommended for winch installation.
2. Check your mounting plate or bumper has suitable screw holes, if not, drill four mounting holes according to the bolt pattern mentioned in the winch specifications.

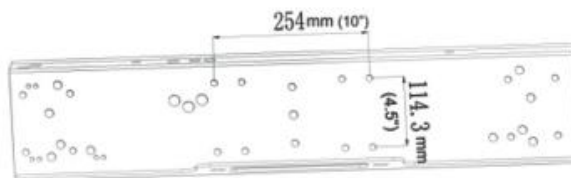

(Pictures for reference only)

Fix Your Winch

1. Install your winch on the mounting plate or bumper, make sure to tighten the mounting bolts fully.
2. Make sure the motor, drum and gear box are on the one surface after installation.

QUALITY PARTS AND ACCESSORIES



Triumph House, Sleaford Road, Bracebridge Heath, Lincoln LN4 2NA,
England Telephone: 01522 568000 | E-mail: sales@rimmerbros.com

www.rimmerbros.com

Registered in England No 1234567 | VAT No: 1234567

Install your Winch Fairlead

1. Fix the fairlead on the mounting plate or bumper, all the winch fairleads come pre-drilled.
2. If you use any other mounting platforms, drill two holes for the fairlead installation.
3. Position the holes so that the fairlead opening hole is at least the width of the cable drum and deep enough to accommodate the max & min diameter of the drum with the cable installed.

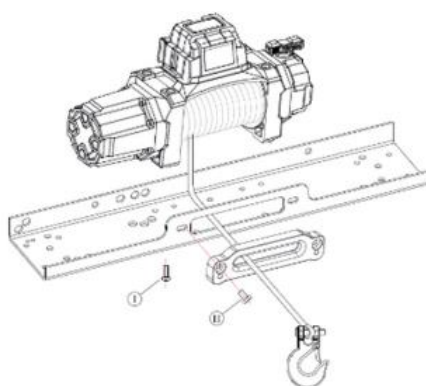

Install Control Box

1. Short red cable connects to the red terminal (A) of the motor
2. Short black cable with yellow jacket connects to the yellow terminal (F-1) of the motor
3. Short black cable with black jacket connects to the black terminal (F-2) of the motor
4. Thin black cable connects to the earth terminal of the motor
5. Long black cable connects to the earth terminal of the motor

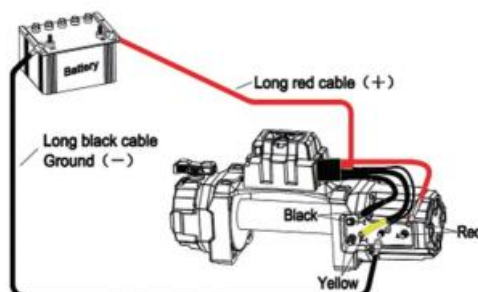

QUALITY PARTS AND ACCESSORIES



Triumph House, Sleaford Road, Bracebridge Heath, Lincoln LN4 2NA,
England Telephone: 01522 568000 | E-mail: sales@rimmerbros.com

www.rimmerbros.com

Registered in England No 1234567 | VAT No: 1234567

Connect Electric Cables

1. Long red cable connects to the Positive (+) of the battery
2. Long black cable connects to the Negative (-) of the battery

Test Your Winch

1. After proper installation and connection, place the clutch in the “Disengaged” position
2. Pull out the winch rope for about 2 metres
3. Turn the clutch to the “Engaged” position
4. Handle the remote control to see if the winch works

If the winch doesn't work, check everything is in accordance with the instructions and all connections are correct and tight or the vehicle batter performance is sufficient. If the winch still does not work after thorough check, please contact your supplier.

After the installation of your winch, we recommend that you take some time and practice using it so you will be familiar with all of its operations. Periodically check the winch installation to ensure that all bolts are tight.

QUALITY PARTS AND ACCESSORIES



Triumph House, Sleaford Road, Bracebridge Heath, Lincoln LN4 2NA,
England Telephone: 01522 568000 | E-mail: sales@rimmerbros.com

www.rimmerbros.com

Registered in England No 1234567 | VAT No: 1234567